

# HK INSTRUMENTS

USER-FRIENDLY MEASURING DEVICES



## AVT AIR VELOCITY TRANSMITTER

USER GUIDE



# CONTENTS

<b>1 Introduction.....</b>	<b>3</b>
1.1 About this user guide.....	3
1.2 Intended use.....	3
<b>2 Safety precautions.....</b>	<b>4</b>
<b>3 Description of the product.....</b>	<b>5</b>
3.1 Main components.....	5
3.2 Technical specifications.....	6
3.3 Dimensions.....	7
<b>4 Commissioning.....</b>	<b>9</b>
4.1 Setting the jumpers.....	9
4.1.1 Selecting the measurement range.....	9
4.1.2 Selecting the output mode.....	9
4.1.3 Terminating Modbus.....	10
4.2 Mounting the product.....	10
4.3 Wiring.....	12
4.3.1 Wiring for Modbus models (-MOD).....	13
4.4 Warm-up mode.....	14
4.5 Configuring settings via device menu.....	14
4.5.1 Available settings for velocity and temperature.....	16
4.5.2 Relay settings.....	19
4.5.3 The Exit menu view.....	19
4.5.4 Available settings for Modbus.....	19
4.6 Locking the cover.....	20
<b>5 Maintenance.....</b>	<b>22</b>
5.1 Cleaning the probe and the sensor element.....	22
<b>6 Modbus.....</b>	<b>23</b>
6.1 Modbus properties.....	23
6.2 Modbus function codes.....	23
6.3 Modbus registers.....	23
6.3.1 Input registers.....	23
6.3.2 Holding registers.....	25
<b>7 Disposal.....</b>	<b>27</b>
<b>8 Warranty policy.....</b>	<b>28</b>

## 1 INTRODUCTION

Thank you for choosing an AVT air velocity transmitter. It is an air velocity and temperature transmitter. The -MOD models have Modbus communication instead of analogue outputs. Other models have one analogue air velocity output and one analogue temperature output.

You can select the measurement range and the output mode for the analogue outputs during commissioning.

The -D models have a display that shows air velocity and temperature measurement values.

The -MOD models have an RS-485 connection for Modbus RTU communication.

The -R model includes a relay and a relay connector.

You can configure the device settings using:

- the device menu (-D models)
- Modbus communication (-MOD models)

### 1.1 ABOUT THIS USER GUIDE

This user guide contains important information about the installation, wiring, configuration and use of the product. Read this guide carefully before you install the product, connect the wires, or operate the product. Make sure that you fully understand all instructions before you start work. If you are not sure what the instructions mean, contact the seller or the manufacturer.

Follow all instructions in this user guide carefully. Always obey the applicable local rules and regulations.

The original instructions were written in English. If there are differences between the English instructions and the translations, refer to the English instructions.

If you find a mistake in the English instructions or in the translations, please send the details to the manufacturer.

### 1.2 INTENDED USE

The AVT air velocity transmitters are intended to be used in commercial environments for measuring air velocity and temperature in ventilation ducts. They are compatible with dry air. The AVT air velocity transmitters are not intended to be used with flammable or corrosive gases.

These transmitters are intended to be connected to building automation systems in the HVAC/R industry.

## 2 SAFETY PRECAUTIONS

The product is developed, manufactured and tested according to high quality standards. However, instructions for safe use must be followed when installing, using or disposing the product or parts of product.

Read this user guide carefully before you commission, use or service this device. To avoid any kind of damage to people or property, follow the instructions carefully. HK Instruments is not liable for any hazards, injury to people, or damage to property caused by incorrect installation or misuse of the device.

To avoid electrical shock or damage to equipment, disconnect power before you install or service the product. Use only proper wiring that is rated for the full operating voltage and maximum current in the system. The wiring must also withstand fault conditions.





To avoid fire and/or explosion, do not use the product in potentially flammable or explosive atmosphere.

Make sure that the product is not damaged before installation. Do not drop the product or use excessive force during installation. Do not use the product if you can see any damages.

After installation, the product will be part of a system whose specifications and performance characteristics are not designed or controlled by HK Instruments. Refer to national and local authorities to ensure that the installation is functional and safe.

The product should only be used in professionally designed applications. Unauthorised modifications are not allowed. The product must not be used in relation with any equipment that in case of a failure may threaten, directly or indirectly, human health or life or result in danger to human beings, animals or property.

In this document, there are different warnings and notes. The warning and note types are defined in the following table.

Sign	Description
 <b>WARNING:</b>	The warning symbol indicates a potentially hazardous situation which, if not avoided, could result in death or serious injury.
 <b>CAUTION:</b>	The caution symbol indicates a potentially hazardous situation which, if not avoided, could result in minor or moderate injury.
 <b>Important:</b>	The important symbol indicates a potentially hazardous situation which, if not avoided, could result in damage to the device or property.
 <b>Note:</b>	The note symbol indicates a useful tip or a recommended way to complete a task. These notes also provide information that is useful but not critical to the user.

### 3 DESCRIPTION OF THE PRODUCT

This section introduces the main parts of the product and contains the technical specifications.

#### 3.1 MAIN COMPONENTS

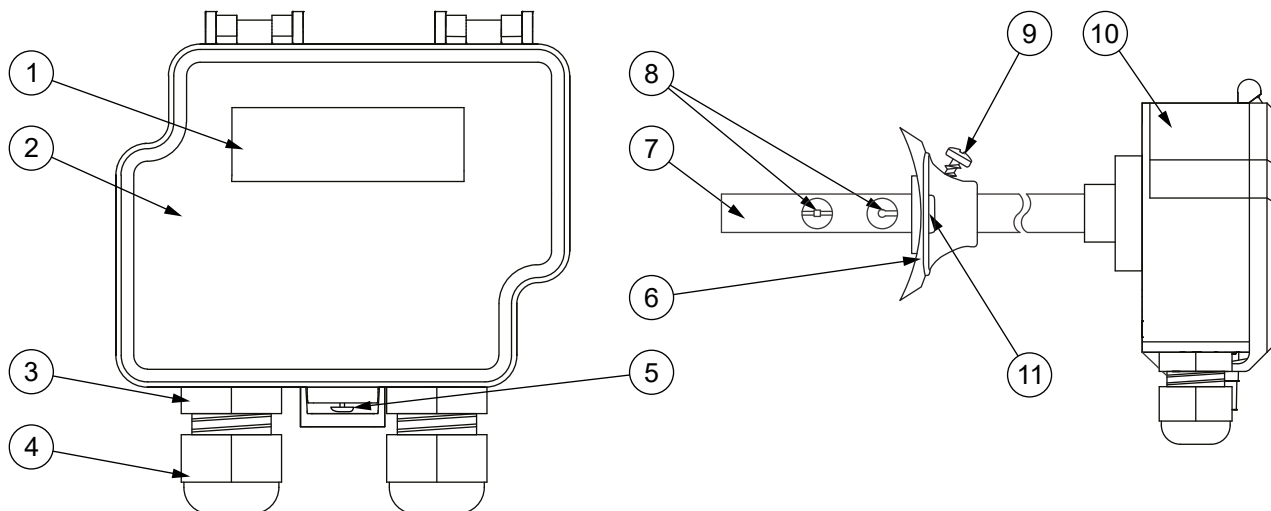

1	Display (-D models)	2	Cover
3	Cable gland	4	Strain relief
5	Cover locking screw (-R models)	6	Duct flange
7	Probe	8	Sensor element
9	Probe locking screw	10	Housing
11	Holes for fixing screws		

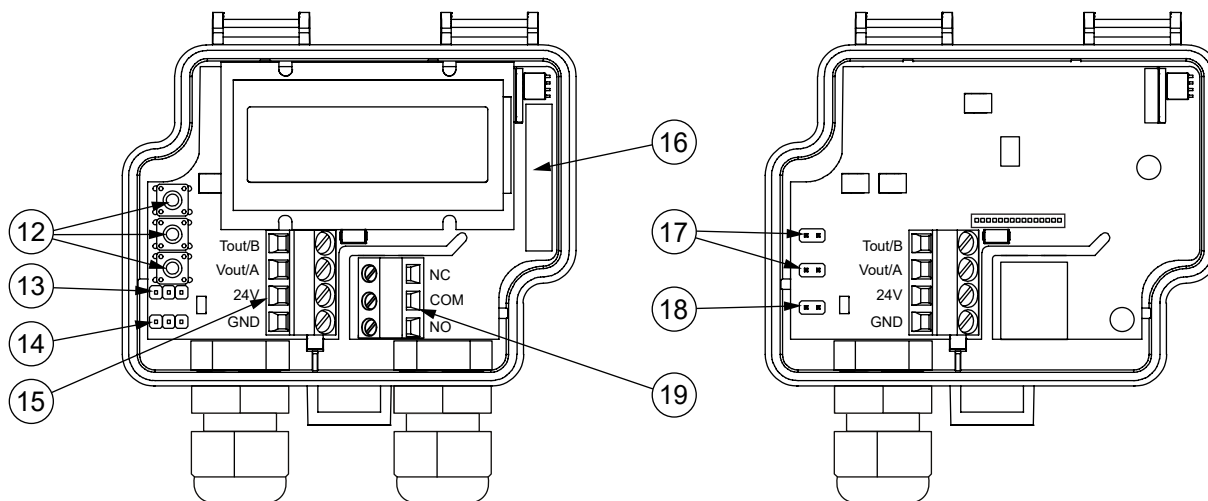

12	Menu buttons (-D models)	13	Jumper for temperature output signal selection (excluding -MOD models)
14	Jumper for air velocity output signal selection (excluding -MOD models)	15	Terminal block
16	Relay (-R models)	17	Measurement range selection jumpers (excluding -D models)
18	Modbus termination jumper (-MOD models)	19	Relay connector (-R models)

## 3.2 TECHNICAL SPECIFICATIONS

Property	Value
Supply	24 Vac/dc $\pm$ 10 %
Current consumption	max. 80 mA + 40 mA with mA output + 10 mA with relay option (DC supply voltage)
Relay (-R models)	250 Vac, 6 A res., adjustable operating direction, switching point and hysteresis
Air velocity measurement	
Measurement range	0...2 m/s, 0...10 m/s, 0...20 m/s, freely selectable
Accuracy (typ. at 25 °C)	$v \geq 0.15$ m/s and $\leq 2$ m/s (0.2 m/s + 2 % from reading) $v > 2$ m/s and $\leq 10$ m/s (0.5 m/s + 3 % from reading) $v > 10$ m/s (1.0 m/s + 3 % from reading)
Temperature measurement	
Measurement range	-25...50 °C (probe)
Accuracy (25 °C)	$\pm 0.5$ °C (air velocity > 0.5 m/s)
Warm-up time	15 seconds
Outputs	
Output signal 1 (T out [C])	0...10 Vdc, load > 1 k $\Omega$ 4...20 mA, load 20...400 $\Omega$
Output signal 2 (v out [m/s])	0...10 Vdc, load > 1 k $\Omega$ 4...20 mA, load 20...400 $\Omega$
Accuracy	Vout: $\pm 0.025$ V at 25 °C  Iout: typically $\pm 0.04$ mA at 25 °C, load 100 $\Omega$ max. $\pm 0.1$ mA at 25 °C, load 20...400 $\Omega$
Relay output (-R models)	3-screw terminal block (NC, COM, NO), potential free SPDT 30 Vdc, 6 A / 230 Vac, 6 A res. (IEC 60664-1 OVC II)
Communication (MOD models)	Modbus RTU
Display (-D models)	2-line display (12 characters/line), 46.0 x 14.5 mm Line 1: velocity / Line 2: temperature (default) Line 1: direction of control output (optional) Line 2: relay status (optional)
Operating conditions	
Temperature	-25...50 °C (probe) 0...50 °C (transmitter housing)
Humidity	0...95 %rH (non-condensing)
IP protection class	IP54, cable downwards / -R and -MOD models: IP54, cables downwards and cables in both cable glands
Wire	0.2...1.5 mm <sup>2</sup> (24...16 AWG)
Cable gland	M16 (2 x M16: -R and -MOD models)

Property	Value	
Mounting	with a duct flange, probe immersion length adjustable: 50...80 mm (probe length 100 mm) 50...180 mm (probe length 200 mm) 50...380 mm (probe length 400 mm)	
<b>Materials</b>		
Housing	ABS plastic	
Cover	PC plastic	
Probe	Stainless steel (AISI 304)	
Duct flange	LLPDP	
Dimensions (w x h x d)	86 x 95 x 168 mm (probe length 100 mm) 86 x 95 x 268 mm (probe length 200 mm) 86 x 95 x 468 mm (probe length 400 mm)	
Weight	220 g	
Storage temperature	-20...70 °C	
Conformance	CE	UKCA
EMC	2014/30/EU	S.I. 2016 No. 1091
RoHS	2011/65/EU + (EU) 2015/863	S.I. 2012 No. 3032
WEEE	2012/19/EU	S.I. 2013 No. 3113
LVD	2014/35/EU	S.I. 2016 No. 1101

### 3.3 DIMENSIONS

All dimensions are in millimeters (mm).

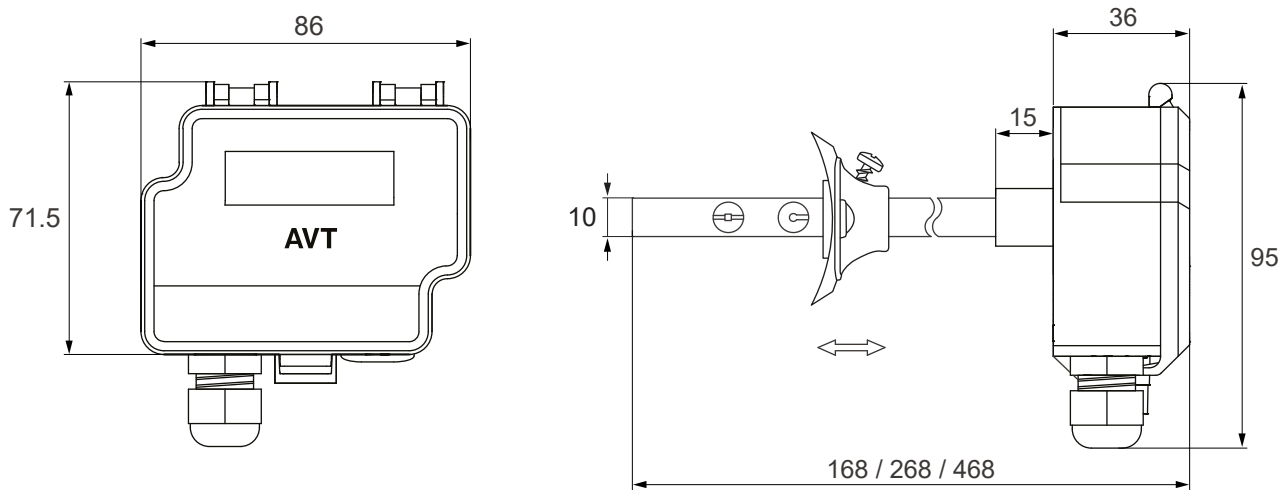

**DUCT FLANGE DIMENSIONS**

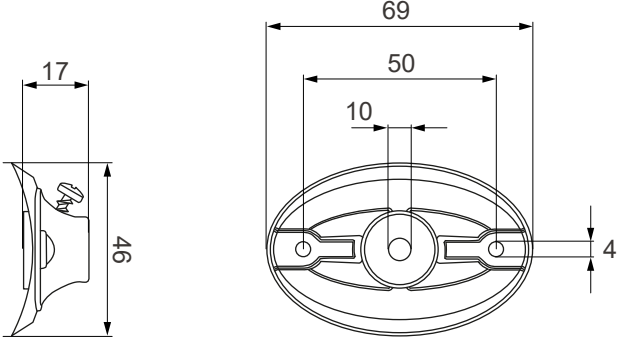



## 4 COMMISSIONING

### 4.1 SETTING THE JUMPERS



**Note:** Set the jumpers in the correct position before you connect the supply voltage to the device.

#### 4.1.1 SELECTING THE MEASUREMENT RANGE

There are different methods for selecting the measurement range. The method used depends on the device options:

- Devices that do not have a display: Select the measurement range by installing jumpers as shown in the table below.
- Models with display (-D): Select the output signal mode with jumpers and then the measurement range via the device menu. See section [Selecting the output mode](#) on page 9

#### SELECTING THE MEASUREMENT RANGE WITH JUMPERS

Install the jumpers according to the table below to select the measurement range for devices that do not have a display.

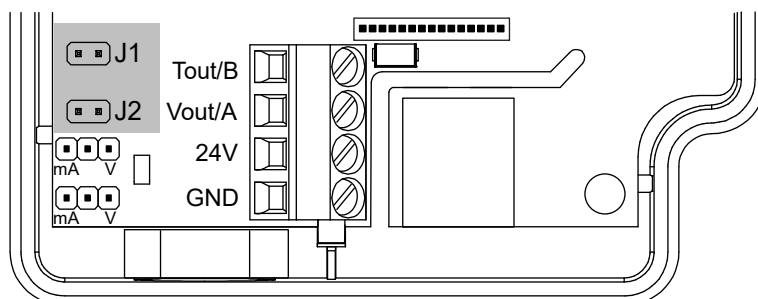

	0...2 m/s	*0...10 m/s	0...20 m/s
J1	■	● ●	■
J2	● ●	■	■
* factory setting			

#### 4.1.2 SELECTING THE OUTPUT MODE

Models with analogue outputs have two jumpers for output signal mode selection on the circuit board. Select the voltage (0...10 V) or the current (4...20 mA) output signal mode based on the system requirements. The current output is not scalable. The voltage output is scalable.

You can configure the output signal separately for air velocity and temperature. Set the jumpers in the correct position to select the output signal mode (V/mA) for air velocity and temperature.

See the table below for the jumper settings.

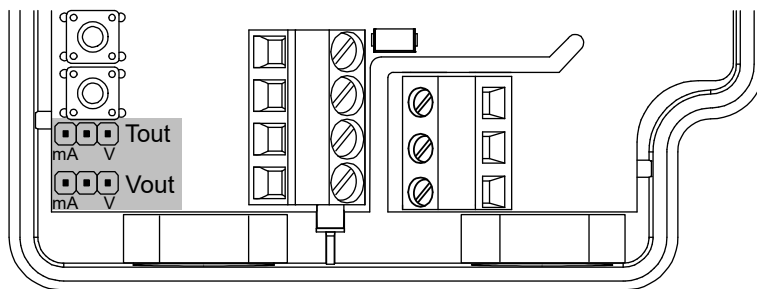

Output					
Temperature output	<i>Tout</i>	Output signal mode: current (mA)	*Output signal mode: voltage (V)	Output signal mode: current (mA)	Output signal mode: voltage (V)
Air velocity output	<i>Vout</i>	Output signal mode: current (mA)	*Output signal mode: voltage (V)	Output signal mode: voltage (V)	Output signal mode: current (mA)
* factory setting					

### 4.1.3 TERMINATING MODBUS

Insert the termination jumper in the last device of the network to terminate the Modbus network.

1. Disconnect the device supply voltage.
2. Open the cover.
3. Insert the termination jumper in position.

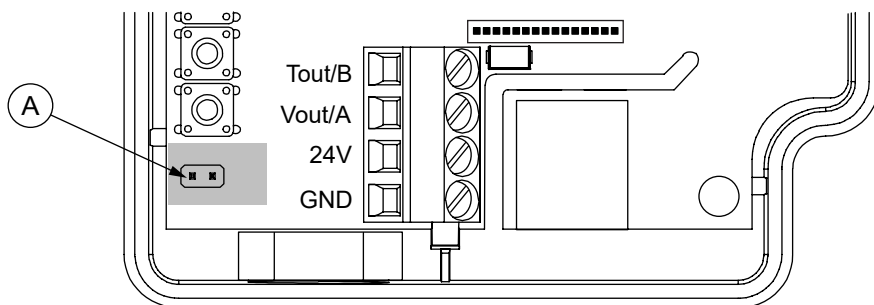

A. Termination jumper

4. Close the cover.

## 4.2 MOUNTING THE PRODUCT



**WARNING:** Handle the product with care. Dropping the product may cause internal damage and unwanted functions in the connected system.



**CAUTION:** Place the product outside the reach of children and animals.



**Important:** The product may only be installed in a location where the ambient conditions meet the operating condition requirements.



**Note:** Remove the device from the air duct before cleaning the duct.

#### Operating conditions

Temperature	-25...50 °C (probe)
	0...50 °C (transmitter housing)
Humidity	0...95 %rH (non-condensing)

1. Check that the product is not damaged during transportation.

2. Select the mounting position on a straight duct.

Measure the length of the straight duct to make sure that the probe is positioned correctly. See the figure below for the required minimum length of straight duct.

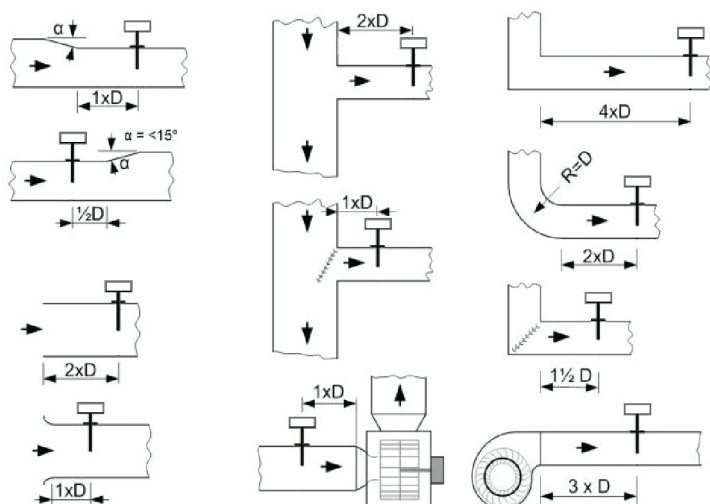

- Round ducts:
  - D = duct diameter
- Rectangular ducts:
  - If there is a horizontal curve or a change in the duct size: D = width of the duct
  - If there is a vertical curve or a change in the duct size: D = height of the duct

3. Use the duct flange as a template and mark the screw holes and the probe hole on the duct.

4. Drill the screw holes and the probe hole on the duct.

The maximum screw diameter is 4 mm. The probe diameter is 10 mm.

5. Mount the duct flange on the duct with screws.

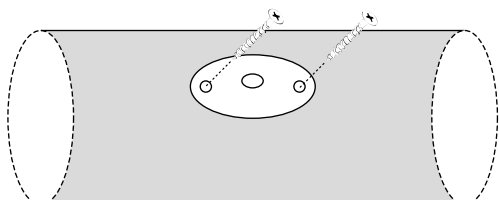

6. Push the transmitter probe into the duct through the hole on the flange.

Make sure that the cable glands of the transmitter point down. See the figure below for the correct mounting orientation.

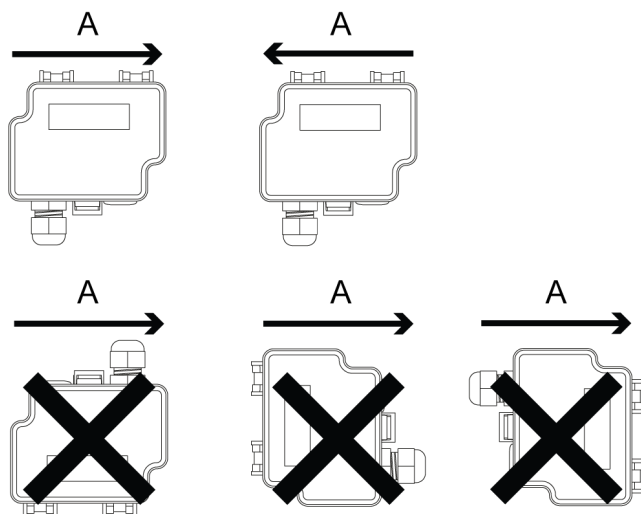





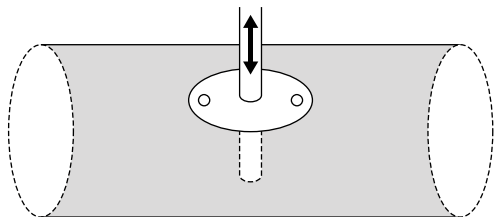

A. Air flow direction

7. Adjust the probe to the correct depth.  
Make sure that the sensor element is in the middle of the duct.



8. Tighten the locking screw on the duct flange to hold the probe in position.

## 4.3 WIRING

-  **WARNING:** Device wiring and commissioning can only be carried out by qualified professionals. Always make the device wirings in de-energised electricity network.
-  **WARNING:** Fuse at load supply (normally 6 A, 10 A, 16 A) does not always limit the relay output load current to 6 A. The relay maximum load is 250 Vac, 6 A res.
-  **WARNING:** Add an external fuse to relay common connector. Use a time-lag fuse (max 6 A) that is in accordance with the standard IEC 60127-2. The product does not have an internal fuse for the relays.
-  **CAUTION:** The product may only be connected to overvoltage category II electricity network according to IEC 60664-1.
-  **CAUTION:** Use single stranded wires or use wire end sleeves if multi stranded wires are used.
-  **Important:** For CE and UKCA compliance, a properly grounded shielding cable is required.

The relay models (-R) and the Modbus (-MOD) models have two cable glands (the left and the right cable gland). Other models only have one cable gland (the left cable gland). See section [Wiring for Modbus models \(-MOD\)](#) on page 13 for Modbus model wiring instructions.

1. Open the cover.
  -  **WARNING:** Do not open the device cover when the relay mains supply voltage is connected. Always do the commissioning of the device in de-energised relay electricity network.
2. Unscrew the strain relief on the left cable gland and route the cables for power in and signal out through the cable gland.
3. For relay models (-R), unscrew the strain relief on the right cable gland and route the cable for the relay through the cable gland.

4. Connect the wires according to the table below.

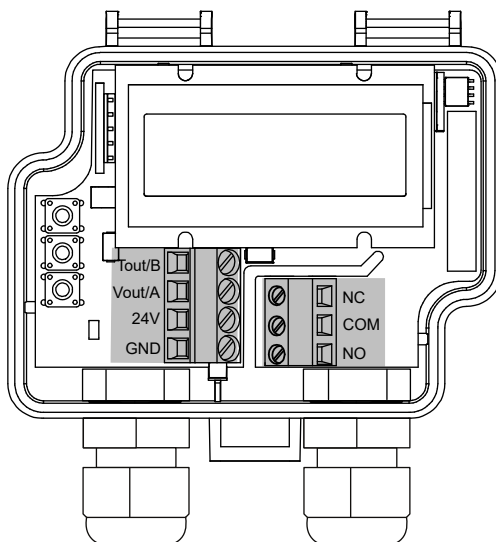

<i>Tout/B</i>	Temperature measurement output signal: 0...10 Vdc, load > 1 kΩ 4...20 mA, load 20...400 Ω
<i>Vout/A</i>	Air velocity measurement output signal: 0...10 Vdc, load > 1 kΩ 4...20 mA, load 20...400 Ω
<i>24V</i>	24 Vac/dc supply
<i>GND</i>	0 V
<i>NC</i>	
<i>COM</i>	Relay output on -R models: 30 Vdc, 6 A / 230 Vac, 6 A res.
<i>NO</i>	

The nominal wiring terminal screw tightening torque is 0.4 Nm.



**Important:** Do not use excessive force when you tighten the wiring terminal screws.

5. Tighten the strain reliefs.

### 4.3.1 WIRING FOR MODBUS MODELS (-MOD)



**Note:** The -MOD models have Modbus communication instead of analogue outputs.



**Important:** For CE and UKCA compliance, a properly grounded shielding cable is required.

It is recommended to use shielded twisted pair cable for Modbus cabling. The cable shield must be earthed only in one point, usually at the end of the main cable.

1. Open the cover.
2. Unscrew the strain relief on the left cable gland.
3. Route the cables for power in and Modbus communication through the left cable gland.
4. To connect this device to the next device in a daisy chain network:
  - a. Unscrew the strain relief on the right cable gland.
  - b. Route the Modbus cable to the next device through the right cable gland.

5. Connect the wires according to the table below.

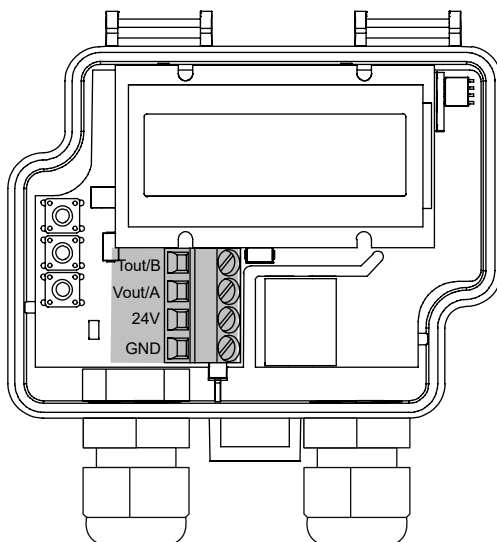

<i>Tout/B</i>	Modbus RTU (RS-485)
<i>Vout/A</i>	
<i>24V</i>	24 Vac/dc supply
<i>GND</i>	0 V

The nominal wire terminal screw tightening torque is 0.4 Nm.



**Important:** Do not use excessive force when you tighten the wiring terminal screws.

6. Tighten the strain reliefs.

## 4.4 WARM-UP MODE

This device starts up in warm-up mode. The warm-up mode continues for 15 seconds after startup. During the warm-up time, the output signals are at the defined minimum values and the relay does not operate. If the device has a display, text *Warming up* is shown on the display. The device starts to operate correctly after the warm-up time.

## 4.5 CONFIGURING SETTINGS VIA DEVICE MENU

See the figure below for the full menu structure for all models with display (-D) excluding the Modbus models (-MOD). For Modbus model menu structure, see section [Available settings for Modbus](#) on page 19.

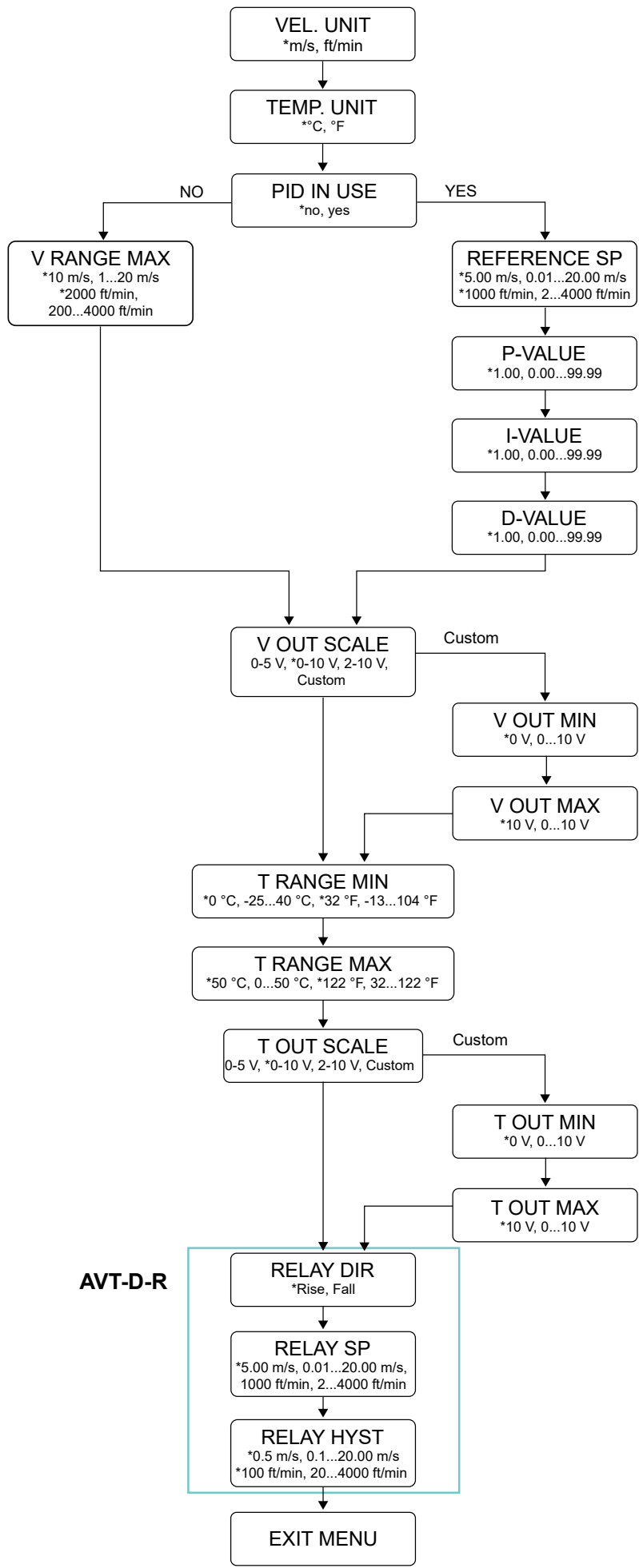

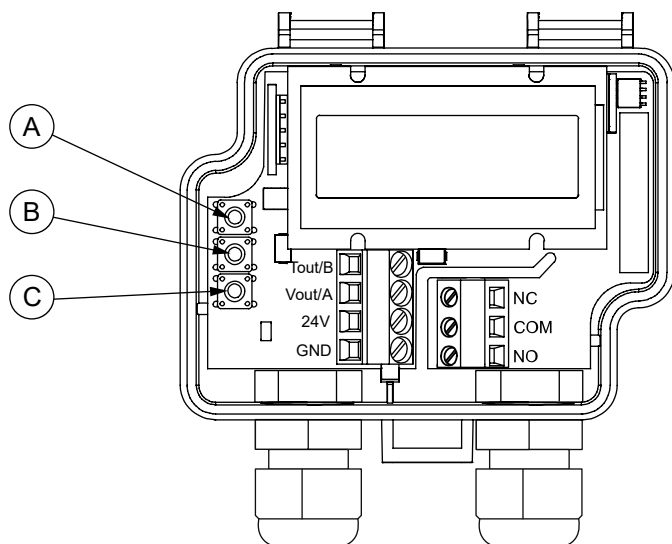

- A. *SELECT* button
- B. *UP* button
- C. *DOWN* button

1. Open the cover.



**WARNING:** Do not open the device cover when the relay mains supply voltage is connected. Always do the commissioning of the device in de-energised relay electricity network.



**CAUTION:** When the power supply is connected, be extra careful when handling the product without the cover.

2. Press the *SELECT* button for two seconds to activate the device menu.
3. Use the *UP* and *DOWN* buttons to navigate the menu.
4. Press the *SELECT* button to change the value of a menu item.
5. Press the *UP* or *DOWN* button to select a value.
6. Press the *SELECT* button to accept the new value and to return to menu navigation.
7. Navigate to the *EXIT MENU* view and press the *SELECT* button to save the settings and exit the menu.

## 4.5.1 AVAILABLE SETTINGS FOR VELOCITY AND TEMPERATURE

For Modbus model settings, see chapter [Available settings for Modbus](#) on page 19.

### 4.5.1.1 THE VEL. UNIT MENU

You can select the velocity unit for the device display and the velocity output in the *VEL. UNIT* menu.

The available velocity units are *m/s* and *ft/min*. The default value is *m/s*.

### 4.5.1.2 THE TEMP. UNIT MENU

You can select the temperature unit for the device display and the temperature output in the *TEMP. UNIT* menu.

The available temperature units are °C and °F. The default value is °C.



### 4.5.1.3 THE PID IN USE MENU

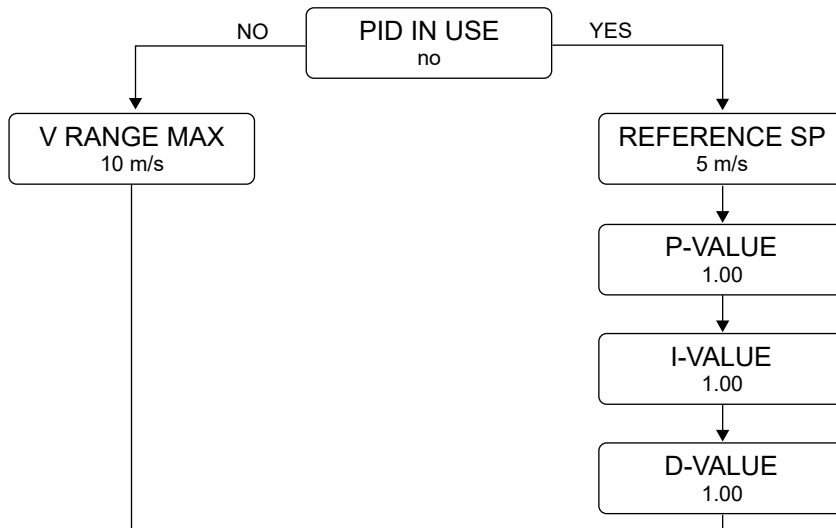

You can select if the PID control function is in use in the *PID IN USE* menu.

The available values are *no* and *yes*. The default value is *no*.

If you select *no*, the next menu item is *V RANGE MAX*.

If you select *yes*, the next menu items are *REFERENCE SP*, *P-VALUE*, *I-VALUE* and *D-VALUE*.

#### THE V RANGE MAX MENU

You can select the maximum value for air velocity measurement range in the *V RANGE MAX* menu.

You can select the maximum velocity measurement range between 1 m/s and 20 m/s. The default value is *10 m/s*.

If you selected *ft/min* in the *VEL. UNIT* menu, you can select the maximum velocity measurement range between 200 ft/min and 4000 ft/min. You can adjust the value by 200 ft/min steps. The default value is *2000 ft/min*.

#### THE REFERENCE SP MENU

You can select the setpoint for the PID controller in the *REFERENCE SP* menu. You can adjust the value by 0.1 m/s or 1 ft/min steps depending on the selected air velocity unit. The default value is *5 m/s* or *1000 ft/min*.

#### THE P-VALUE, I-VALUE AND D-VALUE MENUS

You can select the proportional gain in the *P-value* menu. You can adjust the value by 0.01 unit steps. The default value is *1.00*.

You can select the integral gain in the *I-value* menu. You can adjust the value by 0.01 unit steps. The default value is *1.00*.

You can select the derivative gain in the *D-value* menu. You can adjust the value by 0.01 unit steps. The default value is *1.00*.

You can select the *P-value*, *I-value* and *D-value* between 0 and 99.99.

### 4.5.1.4 THE V OUT SCALE MENU

You can select the air velocity output scale in the *V OUT SCALE* menu.

The available values are *0-5 V*, *0-10 V*, *2-10 V* and *custom*. The default value is *0-10 V*.

If you select *custom*, you can set the minimum and maximum values for the air velocity output scale.

#### THE V OUT MIN MENU

If you selected *custom* in the *V OUT SCALE* menu, you can select the minimum value for the air velocity output scale in the *V OUT MIN* menu.

You can select a value between 0 V and 10 V. You can adjust the value by 1 V steps. The default value is *0 V*.



**Note:** You can select a minimum value that is bigger than the maximum value to reverse the operating direction.

### THE V OUT MAX MENU

If you selected *custom* in the *V OUT SCALE* menu, you can select the maximum value for the air velocity output scale in the *V OUT MAX* menu.

You can select a value between 0 V and 10 V. You can adjust the value by 1 V steps. The default value is 10 V.



**Note:** You can select a maximum value that is smaller than the minimum value to reverse the operating direction.

### 4.5.1.5 THE T RANGE MIN MENU

You can select the minimum value for temperature measurement range in the *T RANGE MIN* menu.

You can select a value between -25 °C and 40 °C. You can adjust the value by 5 °C steps. The default value is 0 °C.

If you selected °F in the *TEMP. UNIT* menu, you can select a value between -13 °F and 104 °F. You can adjust the value by 2 °F steps. The default value is 32 °F.

### 4.5.1.6 THE T RANGE MAX MENU

You can select the maximum value for temperature measurement range in the *T RANGE MAX* menu.

You can select a value between -15 °C and 50 °C. You can adjust the value by 5 °C steps. The default value is 50 °C.

If you selected °F in the *TEMP. UNIT* menu, you can select a value between 5 °F and 122 °F. You can adjust the value by 2 °F steps. The default value is 122 °F.

### 4.5.1.7 THE T OUT SCALE MENU

You can select the temperature output scale in the *T OUT SCALE* menu.

The available values are 0-5 V, 0-10 V, 2-10 V and *custom*. The default value is 0-10 V.

If you select *custom*, you can set the minimum and maximum values for the temperature output scale.

#### THE T OUT MIN MENU

If you selected *custom* in the *T OUT SCALE* menu, you can select the minimum value for the temperature output scale in the *T OUT MIN* menu.

You can select a value between 0 V and 10 V. You can adjust the value by 1 V steps. The default value is 0 V.



**Note:** You can select a minimum value that is bigger than the maximum value to reverse the operating direction.

#### THE T OUT MAX MENU

If you selected *custom* in the *T OUT SCALE* menu, you can select the maximum value for the temperature output scale in the *T OUT MAX* menu.

You can select a value between 0 V and 10 V. You can adjust the value by 1 V steps. The default value is 10 V.



**Note:** You can select a maximum value that is smaller than the minimum value to reverse the operating direction.

## 4.5.2 RELAY SETTINGS

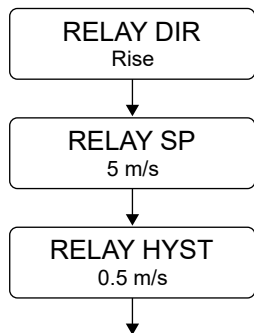

### 4.5.2.1 THE RELAY DIR MENU

This menu is shown only if the transmitter has a relay output (-R models). Relay operating direction defines if the relay switches on or off when the air velocity is more than the setpoint value.

You can select the relay operating direction in the *RELAY DIR* menu. The available values are *Rise* and *Fall*. The relay switches on if *Rise* is selected and the air velocity is more than the setpoint value. If *Fall* is selected, the relay switches on when the air velocity is less than the setpoint value. The default value is *Rise*.

### 4.5.2.2 THE RELAY SP MENU

This menu is shown only if the transmitter has a relay output (-R models).

You can set the velocity setpoint for the relay in the *RELAY SP* menu. You can set this value with an accuracy of two decimals. The default value is *5 m/s* or *1000 ft/min*.

### 4.5.2.3 THE RELAY HYST MENU

This menu is shown only if the transmitter has a relay output (-R models). This setting defines how much the air velocity must drop below the setpoint before the relay switches off if *Rise* is selected in the *RELAY DIR* menu. The function is opposite if *Fall* is selected in the *RELAY DIR* menu.

You can set the hysteresis value for the relay in the *RELAY HYST* menu. You can select a value between 0.1 and 20.0 m/s. You can adjust the value by 0.1 m/s steps. The default value is *0.5 m/s*.

If you selected *ft/min* in the *VEL. UNIT* menu, you can select a value between 20 ft/min and 4000 ft/min. You can adjust the value by 20 ft/min steps. The default value is *100 ft/min*.

## 4.5.3 THE EXIT MENU VIEW

Navigate to the *EXIT MENU* view and press the *SELECT* button to save the settings and exit the menu.

## 4.5.4 AVAILABLE SETTINGS FOR MODBUS

The figure below shows the menu structure for the Modbus models with display (-MOD-D). These menu settings are only available in the Modbus models.

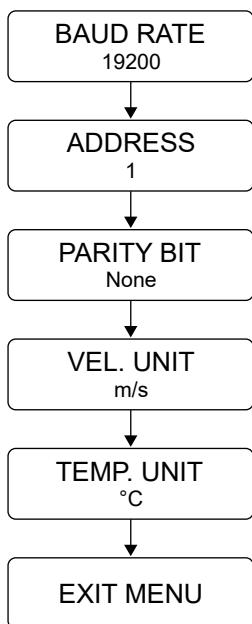

#### 4.5.4.1 THE BAUD RATE MENU

You can select the bus speed in the *BAUD RATE* menu.

The bus speed can be 9600, 19200 or 38400 bits/s. The default baud rate is 19200 bits/s.

#### 4.5.4.2 THE ADDRESS MENU

You can select the Modbus address in the *ADDRESS* menu.

Address range is 1...247. The default value is 1.

#### 4.5.4.3 THE PARITY BIT MENU

You can select Modbus parity in the *PARITY BIT* menu.

The available values for bus parity are *none*, *odd* and *even*. The default setting is *none*.

#### 4.5.4.4 THE VEL. UNIT MENU

You can select the velocity unit for the device display and the velocity output in the *VEL. UNIT* menu.

The available velocity units are *m/s* and *ft/min*. The default value is *m/s*.

#### 4.5.4.5 THE TEMP. UNIT MENU

You can select the temperature unit for the device display and the temperature output in the *TEMP. UNIT* menu.

The available temperature units are °C and °F. The default value is °C.

#### 4.5.4.6 THE EXIT MENU VIEW

Navigate to the *EXIT MENU* view and press the *SELECT* button to save the settings and exit the menu.

## 4.6 LOCKING THE COVER



**WARNING:** There is a hazardous voltage inside the R-model devices. Always lock the cover before the relay mains supply voltage is connected.

1. Close the cover.

2. Tighten the cover locking screw (-R models).

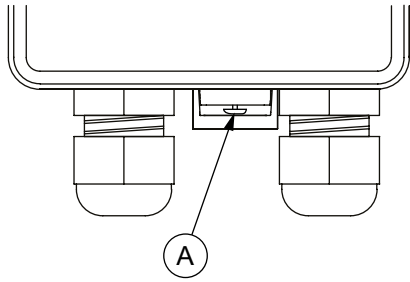

A. Cover locking screw

3. Make sure that the cover does not open without tools.

## 5 MAINTENANCE

### 5.1 CLEANING THE PROBE AND THE SENSOR ELEMENT

Dust, grease and other dirt can accumulate on the sensor element over time and decrease the measurement accuracy of the sensors. Clean the probe and the sensor element regularly. The required cleaning interval depends on the air cleanliness.

Do not clean the sensor element with detergents or other chemicals.

1. Disconnect the device supply voltage. For the -R models, disconnect the device supply voltage and the relay mains supply voltage.
2. Clean the probe with a soft cloth.

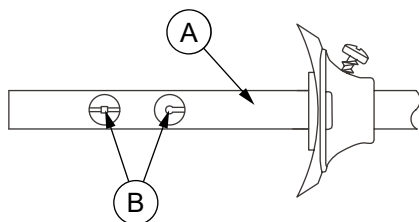

- A. Probe
- B. Sensor element

3. Clean the sensor element with compressed air.

Apply compressed air lightly to the sensor element to prevent damage.



**Important:** Do not use too high pressure, touch the sensor element or use other cleaning methods that cause mechanical stress. Mechanical stress damages the sensor element and changes the measurement accuracy of the sensors.

## 6 MODBUS

### 6.1 MODBUS PROPERTIES

The Modbus communication is only available in -MOD models.

The parameter memory durability allows at least 1 000 writing cycles.



**Note:** The changes to the Modbus communication settings take effect after you restart the device.

Protocol	RS-485 Modbus RTU
Bus speed	9600/19200*/38400 bit/s
Data bits	8
Parity	none*/odd/even
Stop bits	1
Modbus ID	1*
Unit load	1/8 UL

\* factory setting

### 6.2 MODBUS FUNCTION CODES

The device supports the following Modbus function codes.

Decimal	Hexadecimal	Function
3	0x03	Read Holding Registers
4	0x04	Read Input Registers
6	0x06	Write Single Register
16	0x10	Write Multiple Registers

### 6.3 MODBUS REGISTERS

#### 6.3.1 INPUT REGISTERS

##### GENERAL

Register	Parameter description	Data type	Values	Range
0	Velocity m/s	U16	0...2000	0...20 m/s
1	Velocity ft/min	U16	0...4000	0...4000 ft/min
2	Temperature °C	S16	-250...500	-25.0...50.0 °C
3	Temperature °F	S16	-130...1220	-13.0...122.0 °F
4...99	Reserved for future use			

##### DEVICE MODEL DETAILS

Register	Parameter description	Data type	Values	Range
9800	Register count	U16	0...99	0...99
9801	Format version	U16	0...65535	0...65535
9802	Display	U16	0...1	0. no 1. yes

Register	Parameter description	Data type	Values	Range
9803	Buttons	U16	0...1	0. no 1. yes
9804	Number of relays	U16	0...1	0...1
9805	Analogue outputs	U16	0...1	0. no 1. yes
9806	Modbus	U16	0...1	0. no 1. yes
9807	Connector for	U16	0...1	0. no 1. yes
9808	PID controller	U16	0...1	0. no 1. yes

## DEVICE INFORMATION

Register	Parameter description	Data type	Values	Range
9900	Device type	U16	0...65535	0...65535
9901	Hardware version	U16	0...65535	0...65535
9902	Production number, most significant word	U16	0...65535	0...65535
9903	Production number, least significant word	U16	0...65535	0...65535
9904	Configuration number, most significant word	U16	0...65535	0...65535
9905	Configuration number, least significant word	U16	0...65535	0...65535
9906...9908	Reserved for MyTool®	U16		
9909	Ethernet MAC address 1	U16	0	0
9910	Ethernet MAC address 2	U16	0	0
9911	Ethernet MAC address 3	U16	0	0
9912	Wireless MAC address 1	U16	0	0
9913	Wireless MAC address 2	U16	0	0
9914	Wireless MAC address 3	U16	0	0
9915	Memory state	U16	0...9	0. Idle 1. Loading latest configuration 2. Saving latest configuration 3. Loading default configuration 4. Saving default configuration 5. Loading calibration 6. Saving calibration 7. Saving application state 8. Chip erase in progress 9. Cloud configuration management
9916	Configuration compatibility number	U16	0...65535	0...65535
9917	Firmware ID, most significant word	U16	0...65535	0...65535



Register	Parameter description	Data type	Values	Range
9918	Firmware ID, least significant word	U16	0...65535	0...65535
9919	Firmware version (major, minor)	U16	0...65535	0...65535
9920	Firmware version (revision, build)	U16	0...65535	0...65535
9921...9923	Reserved for MyTool®	U16	25	25
9924	MyTool® compatibility number	U16	0	0. Compatibility number not assigned (feature is not in use)

## 6.3.2 HOLDING REGISTERS

### MODBUS

Register	Parameter description	Data type	Values	Range	Default
0	Bus speed	U16	0...2	0. 9600 1. 19200 2. 38400	1
1	Address	U16	1...247	1...247	1
2	Parity bit	U16	0...2	0. none 1. even 2. odd	0
3	Velocity unit	U16	0...1	0. m/s 1. ft/min	0
4	Temperature unit	U16	0...1	0. Celsius 1. Fahrenheit	0
5...199	Reserved for future use				

### MYTOOL

Register	Parameter description	Data type	Values	Range	Default
200	PID in use	U16	0...1	0. no 1. yes	0
201	Velocity range max. (m/s)	U16	1...20	1...20 m/s	10
202	Velocity range max. (ft/min)	U16	2...40	200...4000 ft/min	20
203	Velocity control setpoint (m/s)	U16	1...2000	0.01...20 m/s	500
204	Velocity control setpoint (ft/min)	U16	2...4000	2...4000 ft/min	1000
205	Velocity control P factor	U16	0...9999	0...99.99	100
206	Velocity control I factor	U16	0...9999	0...99.99	100
207	Velocity control D factor	U16	0...9999	0...99.99	100
208	Velocity / velocity control signal scale	U16	0...3	0. 0...5 V 1. 0...10 V 2. 2...10 V 3. Custom	1
209	Velocity / velocity control signal scale custom min.	U16	0...10	0...10 V	0
210	Velocity / velocity control signal scale custom max.	U16	0...10	0...10 V	10
211	Temperature range min. (°C)	U16	-25...40	-25...40 °C	0

Register	Parameter description	Data type	Values	Range	Default
212	Temperature range min. (°F)	U16	-13...104	-13...104 °F	32
213	Temperature range max. (°C)	U16	-15...50	-15...50 °C	50
214	Temperature range max (°F)	U16	5...122	5...122 °F	122
215	Temperature output signal scale	U16	0...3	0. 0...5 V 1. 0...10 V 2. 2...10 V 3. Custom	1
216	Temperature output signal scale custom min.	U16	0...10	0...10 V	0
217	Temperature output signal scale custom max.	U16	0...10	0...10 V	10
218	Relay operating direction	U16	0...1	0. Rise 1. Fall	0
219	Relay setpoint (m/s)	U16	1...2000	0.01...20 m/s	500
220	Relay setpoint (ft/min)	U16	2...4000	2...4000 ft/min	1000
221	Relay hysteresis (m/s)	U16	1...2000	0.01...20 m/s	50
222	Relay hysteresis (ft/min)	U16	2...4000	2...4000 ft/min	100

## 7 DISPOSAL

This device is considered as electrical and electronic equipment for disposal in terms of the applicable European Directive. At the end of life, the product must enter the recycling system at an appropriate collection point.

- The device must be disposed through channels provided for this purpose.
- The disposal must be completed according to the local and currently applicable laws and regulations.

Generally all metals can be recycled as material. Plastics and cardboard packaging material can be used in energy recovery. Printed circuit boards need selective treatment according to IEC 62635 guidelines. To aid recycling, plastic parts are marked with an appropriate identification code. Contact your local HK Instruments distributor for further information on environmental aspects and recycling instructions for professional recyclers.



## 8 WARRANTY POLICY

The seller is obligated to provide a warranty of five years for the delivered goods regarding material and manufacturing. The warranty period is considered to start on the delivery date of the product. If a defect in raw materials or a production flaw is found, the seller is obligated, when the product is sent to the seller without delay or before expiration of the warranty, to amend the mistake at his/her discretion either by repairing the defective product or by delivering free of charge to the buyer a new flawless product and sending it to the buyer. Delivery costs for the repair under warranty will be paid by the buyer and the return costs by the seller. The warranty does not comprise damages caused by accident, lightning, flood or other natural phenomenon, normal wear and tear, improper or careless handling, abnormal use, overloading, improper storage, incorrect care or reconstruction, or changes and installation work not done by the seller. The selection of materials for devices prone to corrosion is the buyer's responsibility, unless otherwise is legally agreed upon. Should the manufacturer alter the structure of the device, the seller is not obligated to make comparable changes to devices already purchased. Appealing for warranty requires that the buyer has correctly fulfilled his/her duties arisen from the delivery and stated in the contract. The seller will give a new warranty for goods that have been replaced or repaired within the warranty, however only to the expiration of the original product's warranty time. The warranty includes the repair of a defective part or device, or if needed, a new part or device, but not installation or exchange costs. Under no circumstance is the seller liable for damages compensation for indirect damage.